

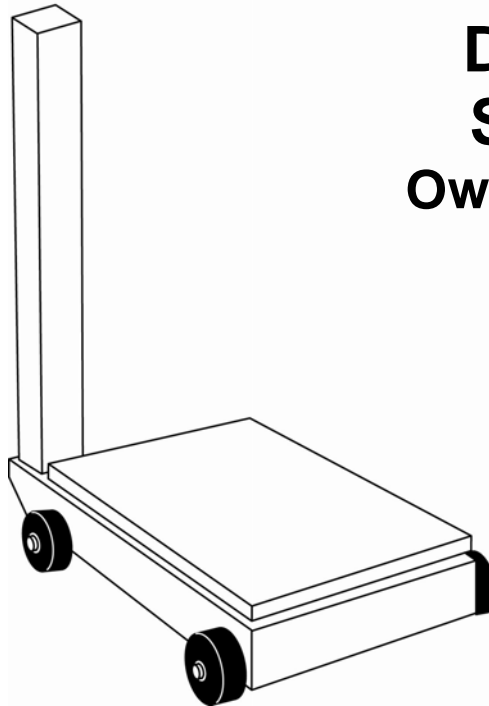

**PORTABLE PLATFORM
SCALES**

**Digital Type
Series 850F
Owner's Manual**



Model 850F



0066-M176-O1 Rev J
11/14

CARDINAL SCALE MFG. CO.
PO Box 151 • Webb City, MO 64870
Ph: 417-673-4631 • Fax: 417-673-5001
www.detectoscale.com

Printed in USA

Technical Support: Ph: 866-254-8261 • techsupport@cardet.com

TABLE OF CONTENTS

Introduction	2
Models and Specifications	2
Scale Base and Column Assembly Instructions	3
5852F-210, 5852F-205 and 8852F-205 Assembly Instructions	5
5852F-204 and 8852F-204 Assembly Instructions	6
5852F-190 and 8852F-190 Assembly Instructions	7
Parts Identification, Scale Base Assembly	8
Parts Identification, Column Assembly	10

FCC COMPLIANCE STATEMENT

This equipment generates uses and can radiate radio frequency and if not installed and used in accordance with the instruction manual, may cause interference to radio communications. It has been tested and found to comply with the limits for a Class A computing device pursuant to Subpart J of Part 15 of FCC rules, which are designed to provide reasonable protection against such interference when operated in a commercial environment. Operation of this equipment in a residential area may cause interference in which case the user will be responsible to take whatever measures necessary to correct the interference.

You may find the booklet "How to Identify and Resolve Radio TV Interference Problems" prepared by the Federal Communications Commission helpful. It is available from the U.S. Government Printing Office, Washington, D.C. 20402. Stock No. 001-000-00315-4.

PROPER DISPOSAL

When this device reaches the end of its useful life, it must be properly disposed of. It must not be disposed of as unsorted municipal waste. Within the European Union, this device should be returned to the distributor from where it was purchased for proper disposal. This is in accordance with EU Directive 2002/96/EC. Within North America, the device should be disposed of in accordance with the local laws regarding the disposal of waste electrical and electronic equipment.

It is everyone's responsibility to help maintain the environment and to reduce the effects of hazardous substances contained in electrical and electronic equipment on human health. Please do your part by making certain that this device is properly disposed of. The symbol shown to the right indicates that this device must not be disposed of in unsorted municipal waste programs.



COPYRIGHT

All rights reserved. Reproduction or use, without expressed written permission, of editorial or pictorial content, in any manner, is prohibited. No patent liability is assumed with respect to the use of the information contained herein.

DISCLAIMER

While every precaution has been taken in the preparation of this manual, the Seller assumes no responsibility for errors or omissions. Neither is any liability assumed for damages resulting from use of the information contained herein. All instructions and diagrams have been checked for accuracy and ease of application; however, success and safety in working with tools depend to a great extent upon the individual accuracy, skill and caution. For this reason the Seller is not able to guarantee the result of any procedure contained herein. Nor can they assume responsibility for any damage to property or injury to persons occasioned from the procedures. Persons engaging the procedures do so entirely at their own risk.

INTRODUCTION

Thank you for purchasing our Detecto Model 850F Series Portable Digital Scale. It has been manufactured with Detecto quality and reliability at our factory in Webb City, Missouri U.S.A. This scale has been calibrated and tested before leaving our factory to insure accuracy and dependability for years to come.

When removing the scale from its packing, inspect it for signs of damage such as exterior dents and scratches. Keep carton and packing material for return shipment if it should become necessary. It is the responsibility of the purchaser to file all claims for any damages or loss incurred during transit, unless this responsibility has been accepted by the Seller in its proposal.

MODELS AND SPECIFICATIONS

MODEL	CAPACITY	INDICATOR
850F	1,000 lb / 440 kg	Not Included
5852F-210	500 lb x .2 lb / 220 kg x .1 kg	210 Indicator
5852F-205	500 lb x .2 lb / 220 kg x .1 kg	205 Indicator
8852F-205	1,000 lb x .5 lb / 440 kg x .2 kg	205 Indicator
5852F-204	500 lb x .2 lb / 220 kg x .1 kg	204 Indicator
8852F-204	1,000 lb x .5 lb / 440 kg x .2 kg	204 Indicator
5852F-190	500 lb x .2 lb / 220 kg x .1 kg	190 Indicator
8852F-190	1,000 lb x .5 lb / 440 kg x .2 kg	190 Indicator

To Order Parts Call Toll Free: 1-800-641-2045

Serial Number _____ Date of Purchase _____ Purchased Form _____ _____ _____ <div style="text-align: center; font-size: small; margin-top: 5px;">RETAIN THIS INFORMATION FOR FUTURE USE</div>
--

<h3 style="margin: 0;">PRECAUTIONS</h3> <p style="margin: 5px 0;">Before using this product, read this manual and pay special attention to all "NOTIFICATION" symbols:</p> <div style="display: flex; align-items: center; justify-content: center; margin-top: 10px;"> <p style="margin: 0;">IMPORTANT</p> </div>

SCALE BASE AND COLUMN ASSEMBLY INSTRUCTIONS



IMPORTANT
Leave strapping on weighbridge until scale is completely assembled.

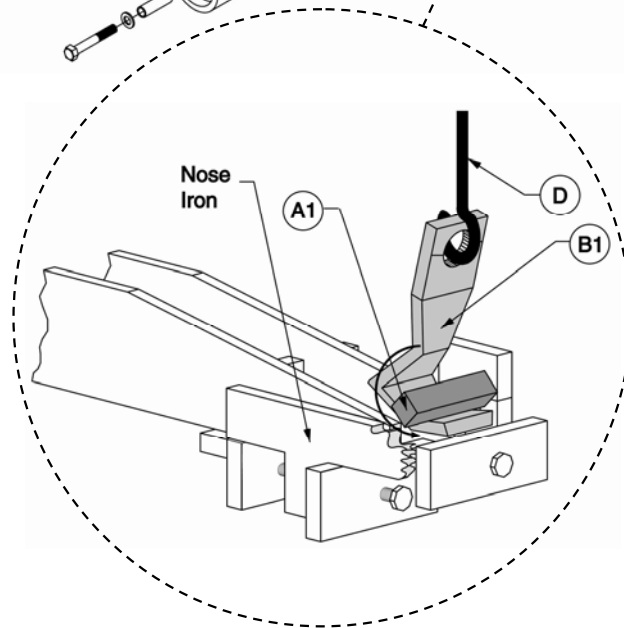
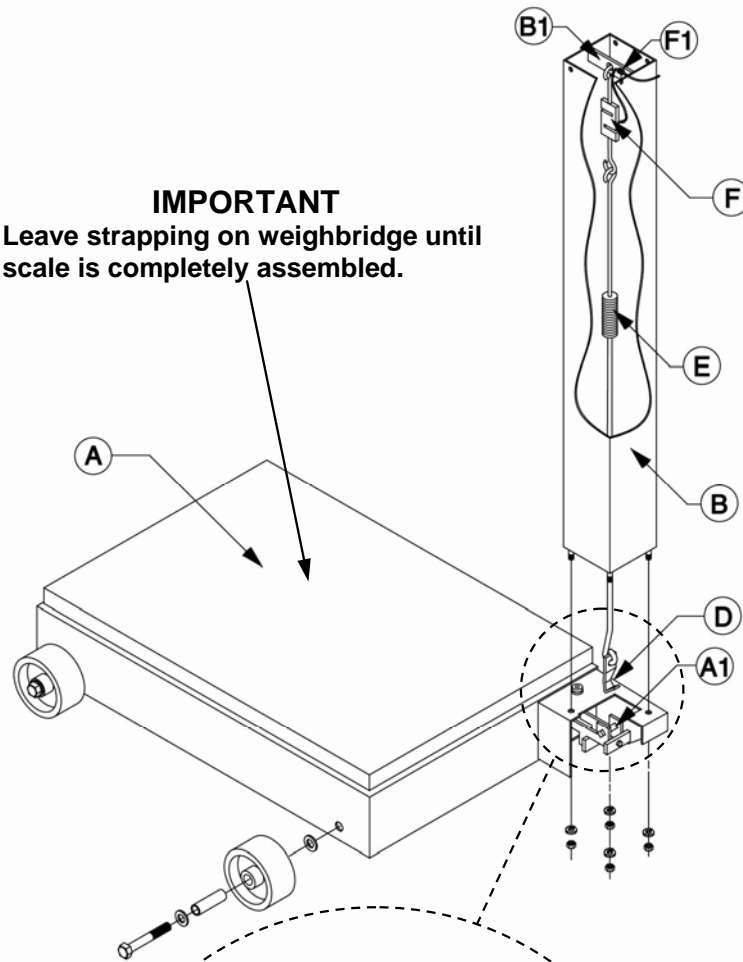

SCALE BASE AND COLUMN ASSEMBLY INSTRUCTIONS, CONT.

Refer to Figure No.1 and follow the instructions provided below for scale assembly.

1. Assemble each wheel to the scale base with four 5/8-11 x 3 1/2" hex head bolts, four sleeves and eight 5/8 flat washers. To secure the wheel, tighten the bolt against the sleeve to scale base.
2. Insert column (B) into scale base assembly (A) and secure with the 3/8" flat washers, 3/8" split lock washers and 3/8-16 hex nuts. **NOTE:** Detecto decal should be facing toward platform.
3. Attach the steelyard hanger (D) to the long end of the shock absorber assembly (E).
4. Partially lower the shock absorber assembly (E) into the column (B) with the open side of the hanger (D) facing towards the back of the scale.
5. Hook the short end of the shock absorber assembly (E) to one end of the load cell assembly (F). **NOTE:** Handle load cell with care!! **DO NOT** drop, bend or twist.
6. Slide the grommet (F1) away from the load cell to the other end of the cable.
7. Slide the grommet (F1) into the slot at the top of the column. **NOTE:** The slot should be on the back side of the column.
8. Lower the load cell and shock absorber assemblies into the column. The hanger (D) must drop through the opening in the scale base assembly.
9. Fasten the top hook bolt of the load cell assembly (F) to the column hanger (B1).
10. Attach the steelyard hanger (D) to the nose iron pivot (A1).
11. Pull out the excess load cell cable in the column leaving enough slack in the cable so as not to have any side pull on the load cell.
12. Before continuing to Step 13, check scale platform for ease of movement. If rubbing or binding, check to make sure the scale has been correctly assembled. If it has been properly assembled, **DO NOT** attempt to adjust the long lever nose iron (A1), contact your Detecto dealer. The nose iron has been preset at the factory. **NOTE:** Scale set up and operation must be on a level surface. The scale is level when the air bubble is in the target on the bulls-eye level.
13. Scale base and column assembly is complete. Refer to the Digital Indicator Instructions which apply to your model of scale for further assembly instructions. Or refer to the information below for load cell wiring identification of the 850F Model.

Color	Function
Green	+ Excitation
Black	- Excitation
Red	+ Signal
White	- Signal
Shield	Shield

5852F-210, 5852F-205 AND 8852F-205 ASSEMBLY INSTRUCTIONS

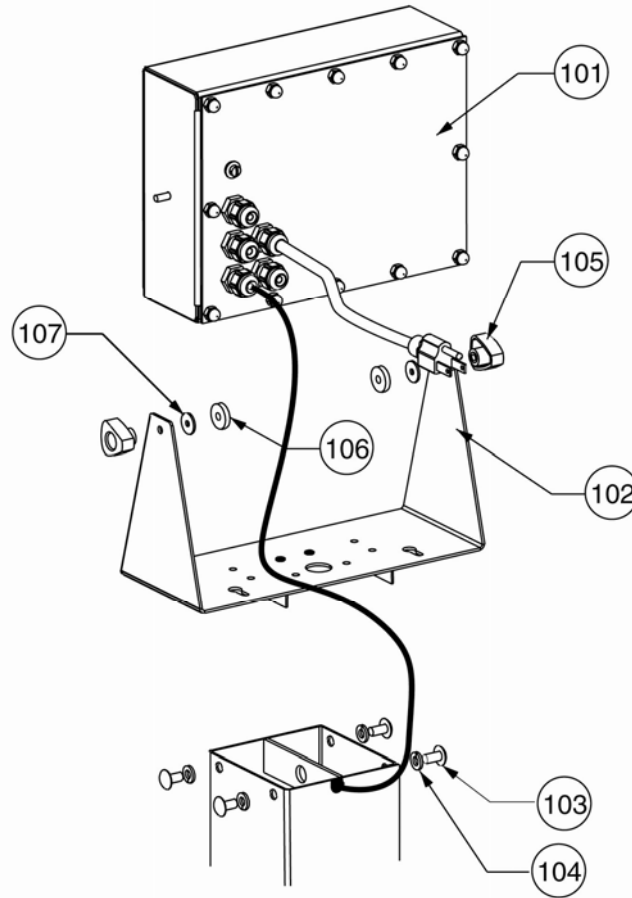

IMPORTANT: Handle must be installed before the gimbal/column top plate assembly. Refer to COLUMN ASSEMBLY illustration on page 10.

1. Assemble gimbal/column top plate assembly (102) to column using four 1/4-20 x 3/4" hex head machine screws and four 1/4 split lock washers (103, 104).
2. Mount the digital weight indicator (101) to the gimbal (102) and secure with two knobs, two washers and two spacers (105, 106, 107). **NOTE:** Do not tighten these knobs tight. The indicator should be free to be adjusted later at the operator's convenience.
3. Connect and secure the load cell cable into the back of the indicator via the 9 pin connector. Refer to Indicator Manual 8200-M129-O1 or 8200 M585-O1.
4. Refer to Indicator Manual 8200-M129-O1 or 8200 M585-O1 for setup instructions.

Parts List

Item	Part Number	Description	Qty
101	205/210	Digital Weight Indicator	1
102	8200-D022-08	Gimbal	1
103	6021-1454	1/4-20 x 3/4" Hex Head Machine Screw	4
104	6024-0039	1/4 Split Lock Washer	4
105	6540-1053	Enclosure Knob	2
106	6540-1008	Spacer	2
107	6024-0083	Washer	2

5852F-204 AND 8852F-204 ASSEMBLY INSTRUCTIONS

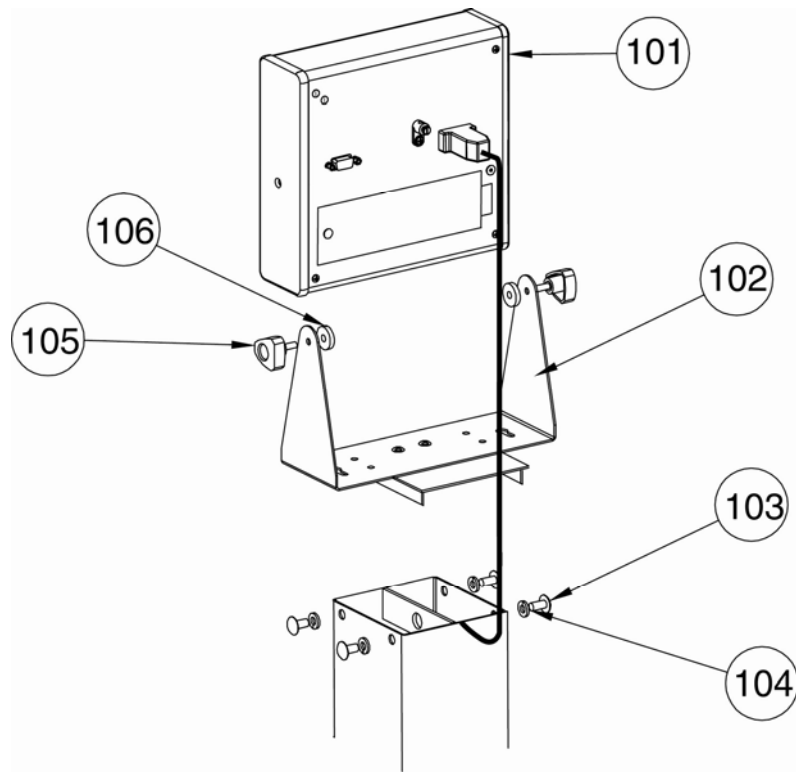

IMPORTANT: Handle must be installed before the gimbal/column top plate assembly. Refer to COLUMN ASSEMBLY illustration on page 10.

1. Assemble gimbal/column top plate assembly (102) to column using four 1/4-20 x 3/4" hex head machine screws and four 1/4 split lock washers (103, 104).
2. Mount the digital weight indicator (101) to the gimbal (102) and secure with two knobs and two spacers (105, 106). **NOTE:** Do not tighten these knobs tight. The indicator should be free to be adjusted later at the operator's convenience.
3. Connect and secure the load cell cable into the back of the indicator via the 9 pin connector. Refer to Indicator Manual 8555-M313-O1.
4. Refer to Indicator Manual 8555-M313-O1 for setup instructions.

Parts List

Item	Part Number	Description	Qty
101	204	Digital Weight Indicator	1
102	8555-C146-08	Gimbal	1
103	6021-1454	1/4-20 x 3/4" Hex Head Machine Screw	4
104	6024-0039	1/4 Split Lock Washer	4
105	6540-1052	Enclosure Knob	2
106	6540-1008	Spacer	2

5852F-190 AND 8852F-190 ASSEMBLY INSTRUCTIONS

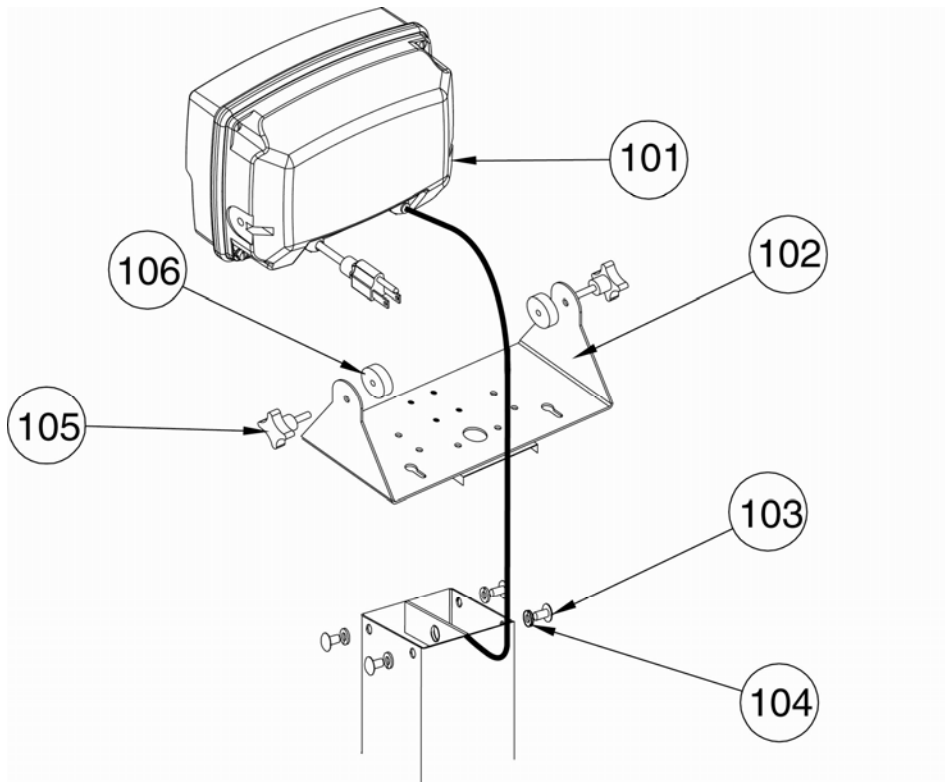

IMPORTANT: Handle must be installed before the gimbal/column top plate assembly. Refer to COLUMN ASSEMBLY illustration on page 10.

1. Assemble gimbal/column top plate assembly (102) to column using four 1/4-20 x 3/4" hex head machine screws and four 1/4 split lock washers (103, 104).
2. Mount the digital weight indicator (101) to the gimbal (102) and secure with two knobs and two washers (105, 106). **NOTE:** Do not tighten these knobs tight. The indicator should be free to be adjusted later at the operator's convenience.
3. Refer to Indicator Manual 8400-M022-O1 to connect and secure the load cell cable into the back of the indicator.
4. Refer to Indicator Manual 8400-M022-O1 for setup instructions.

Parts List

Item	Part Number	Description	Qty
101	190	Digital Weight Indicator	1
102	8400-C004-08	Gimbal	1
103	6021-1454	1/4-20 x 3/4" Hex Head Machine Screw	4
104	6024-0039	1/4 Split Lock Washer	4
105	6540-0332	Enclosure Knob	2
106	8400-B001-08	Rubber Gimbal Washer	2

PARTS IDENTIFICATION

SCALE BASE ASSEMBLY

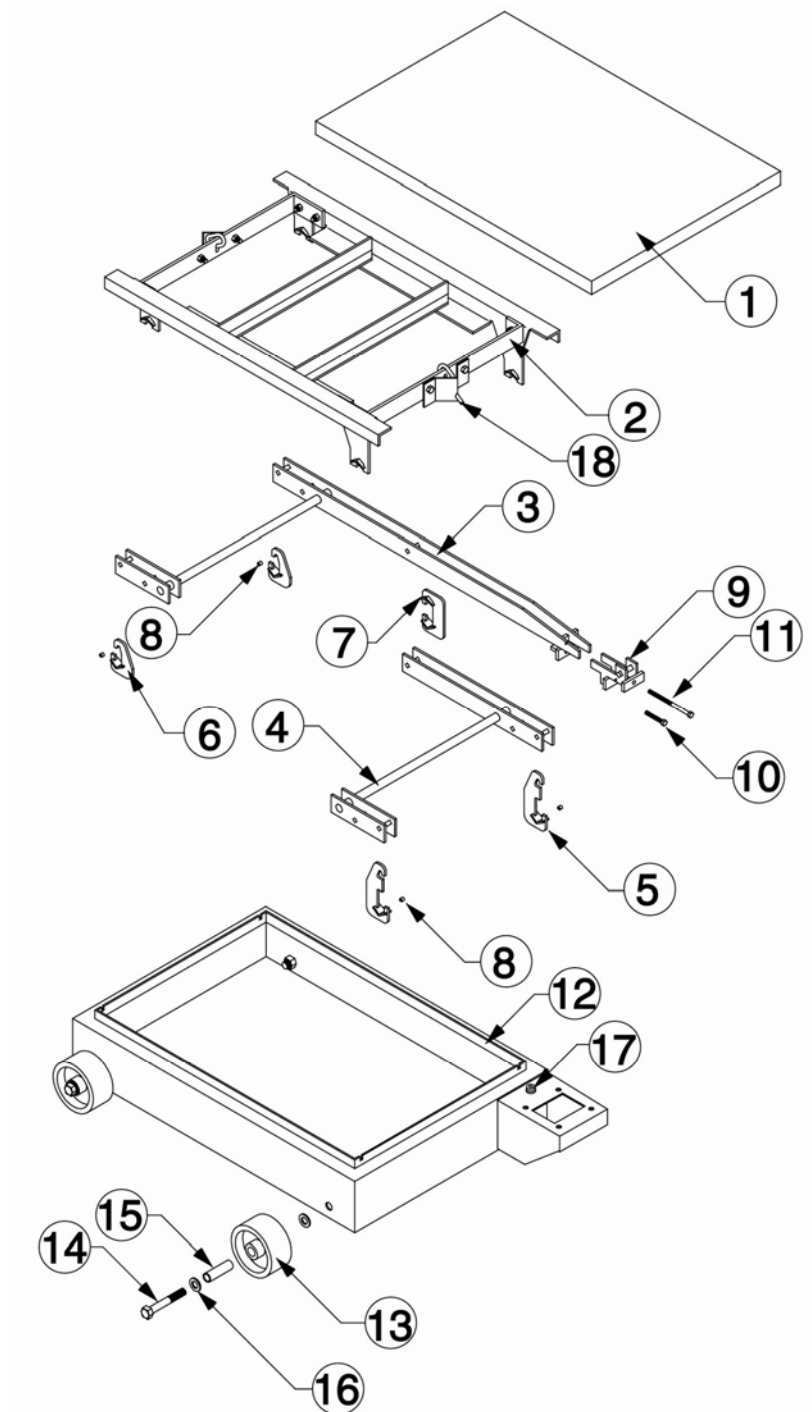

PARTS IDENTIFICATION, CONT.
SCALE BASE ASSEMBLY

Item	Qty	Part Number	Description
1	1	0066-C017-08	Deck Plate
2	1	0066-D012-0A	Weighbridge Assembly
3	1	0066-D006-0A	Long Lever Assembly
4	1	0066-D007-0A	Short Lever Assembly
5	2	0066-B004-0A	Long Hanger Assembly
6	2	0066-B005-0A	Short Hanger Assembly
7	1	0066-B008-0A	Center Hanger Assembly
8	4	0066-B003-08	Bearing
9	1	0066-B010-0A	Nose Iron Assembly
10	1	6021-1458	5/16 -18UNC x 1 3/4" Hex head Bolt
11	1	6021-1833	5/16 -18UNC x 4" Hex head Bolt
12	1	0066-D002-0A	Base Weldment
13	4	0066-B199-08	5" Rubber Wheel
14	4	6007-0240	5/8 -11 x 3 1/2" Hex head Bolt
15	4	0066-B200-08	Sleeve
16	8	6024-0015	5/8 Flat Washer
17	1	6690-0001	Bulls-eye Level
18	2	0066-B016-08	Check Rod

PARTS IDENTIFICATION, CONT.

COLUMN ASSEMBLY

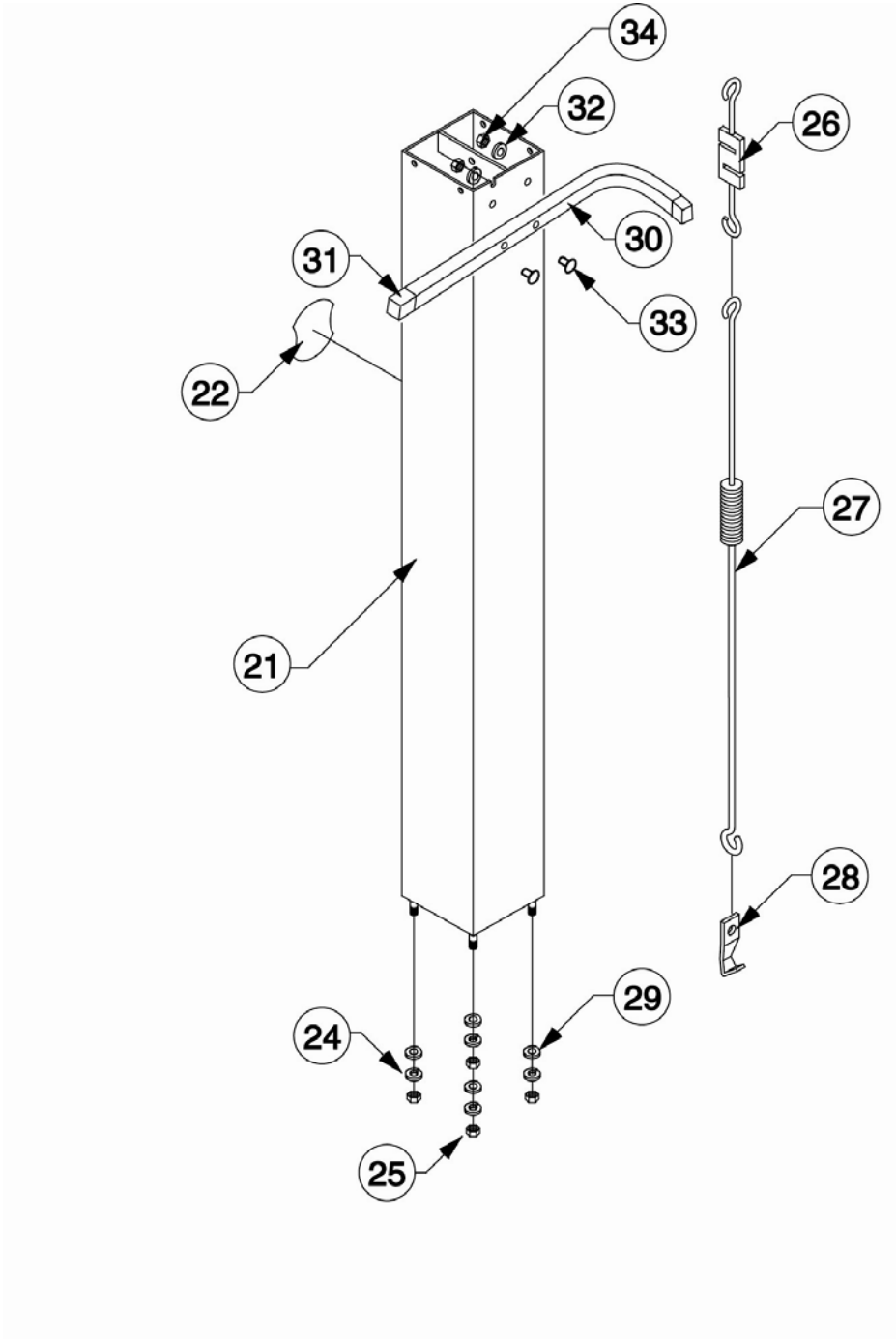

**PARTS IDENTIFICATION, CONT.
COLUMN ASSEMBLY**

Item	Qty	Part Number	Description
21	1	0066-B100-0A	Column Assembly
22	1	6PSS1002	Detecto Logo Decal
24	4	6024-0045	3/8 Split Lock Washer
25	4	6P23	3/8-16 Hex Jam Nut
26	1	709G2R1206	Load Cell Assembly (5852F-204, 8852F-204, 8852F-190)
	1	709GR1215	Load Cell Assembly (5852F-205, 8852F-205, 5852F-210, 5852F-190)
27	1	568GR404	Shock Absorber
28	1	6P32	Hanger
29	4	6024-0009	3/8 Flat Washer

HANDLE ASSEMBLY

Item	Qty	Part Number	Description
30	1	0066-B079-08	Handle
31	2	6540-1069	Cap Vinyl 3/4" Sq x 1" Long Black
32	2	6024-0003	Washer Flat 9/32 ID x 5/8 OD x 1/16 TK
33	2	6021-1426	Hex Washer Machine Screw .25-20x1.25
34	2	391RV204	Nut 1/4-20 Elastic Stop Z/P

TOP PLATE ASSEMBLY*

Qty	Part Number	Description
1	430GR8630	Top Plate Assembly
4	6024-0039	Washer Lock Helical SP 1/4" Reg Z-PL
4	6021-1454	1/4-20 x 3/4" Hex Head Machine Screw

* Not Shown

STATEMENT OF LIMITED WARRANTY

Detecto Scale warrants its equipment to be free from defects in material and workmanship as follows: Detecto warrants to the original purchaser only that it will repair or replace any part of equipment which is defective in material or workmanship for a period of **two (2) years from date of shipment**. Detecto shall be the sole judge of what constitutes a defect.

During the **first ninety (90) days** Detecto may choose to replace the product at no charge to the buyer upon inspection of the returned item.

After the first ninety (90) days, upon inspection of the returned item, Detecto will repair or replace it with a remanufactured product. The customer is responsible for paying for the freight both ways.

This warranty does not apply to peripheral equipment not manufactured by Detecto; this equipment will be covered by certain manufacturer's warranty only.

This warranty does not include replacement of expendable or consumable parts. This does not apply to any item which has deteriorated or damaged due to wear, accident, misuse, abuse, improper line voltage, overloading, theft, lightning, fire, water or acts of God, or due to extended storage or exposure while in purchaser's possession. This warranty does not apply to maintenance service. Purchased parts will have a ninety (90) day repair or replacement warranty only.

Detecto may require the product to be returned to the factory; item(s) must be properly packed and shipping charges prepaid. A return authorization number must be obtained for all returns and marked on the outside of all returned packages. Detecto accepts no responsibility for items lost or damaged in transit.

Conditions Which Void Limited Warranty

This warranty shall not apply to equipment which:

- A.) Has been tampered with, defaced, mishandled or has had repairs and modifications not authorized by Detecto.
- B.) Has had serial number altered, defaced, or removed.
- C.) Has not been properly grounded according to Detecto's recommended procedure.

Freight Carrier Damage

Claims for equipment damaged in transit must be referred to the freight carrier in accordance with freight carrier regulations.

This warranty sets forth the extent of our liability for breach of any warranty or deficiency in connection with the sale or use of the product. Detecto will not be liable for consequential damages of any nature, including but not limited to, loss of profit, delays or expenses, whether based on tort or contract. Detecto reserves the right to incorporate improvements in material and design without notice and is not obligated to incorporate improvements in equipment previously manufactured.

The foregoing is in lieu of all other warranties, express or implied including any warranty that extends beyond the description of the product including any warranty of merchantability or fitness for a particular purpose. This warranty covers only those Detecto products installed in the forty-eight (48) contiguous continental United States.



Ph. (800) 641-2008
E-mail: detecto@cardet.com
203 E. Daugherty
Webb City, MO 64870

08/27/2014
Printed in USA
D268-WARRANTY-DET-A

