



# *Cardinal*<sup>®</sup>

# DETECTO

## DIGITAL Pediatric Scale Models 8435 & 8435KG Owner's Manual



8525-M316-O1 Rev A  
02/10

CARDINAL SCALE MFG. CO.  
PO BOX 151 • WEBB CITY, MO 64870  
PH (417) 673-4631 • FAX (417) 673-5001  
[www.detectoscale.com](http://www.detectoscale.com)

Printed in USA

Technical Support: Ph: 866-254-8261 • [techsupport@cardet.com](mailto:techsupport@cardet.com)



# DIGITAL PEDIATRIC SCALE

Thank you for your purchase of our Detecto Model 8435 (8435KG) Digital Pediatric scale. It has been manufactured with quality and reliability at our factory in Webb City, MO USA. Your scale has been tested before leaving our factory to insure accuracy and dependability for years to come.

This manual will guide you through assembly, installation, and operation of your scale. Please read it thoroughly before attempting to use your scale and keep it handy for future reference.

## FCC COMPLIANCE STATEMENT

**WARNING!** This equipment generates uses and can radiate radio frequency and if not installed and used in accordance with the instruction manual, may cause interference to radio communications. It has been tested and found to comply with the limits for a Class A computing device pursuant to Subpart J of Part 15 of FCC rules, which are designed to provide reasonable protection against such interference when operated in a commercial environment. Operation of this equipment in a residential area may cause interference in which case the user will be responsible to take whatever measures necessary to correct the interference.



You may find the booklet "How to Identify and Resolve Radio TV Interference Problems" prepared by the Federal Communications Commission helpful. It is available from the U.S. Government Printing Office, Washington, D.C. 20402. Stock No. 001-000-00315-4.

All rights reserved. Reproduction or use, without expressed written permission, of editorial or pictorial content, in any manner, is prohibited. No patent liability is assumed with respect to the use of the information contained herein. While every precaution has been taken in the preparation of this manual, the Seller assumes no responsibility for errors or omissions. Neither is any liability assumed for damages resulting from use of the information contained herein. All instructions and diagrams have been checked for accuracy and ease of application; however, success and safety in working with tools depend to a great extent upon the individual accuracy, skill and caution. For this reason the Seller is not able to guarantee the result of any procedure contained herein. Nor can they assume responsibility for any damage to property or injury to persons occasioned from the procedures. Persons engaging the procedures do so entirely at their own risk.

## SPECIFICATIONS

Capacity .....	130 lb x 0.1 lb (59 kg x 0.05 kg), selectable
Tray Size .....	22" L x 14.75" W x 4.5" D (56 cm L x 37 cm W x 11 cm D)
Shipping Weight .....	33 lb (15 kg)
Scale Height .....	37 1/2 " (953 mm)
Display .....	Six digit, Seven segment, 0.7 inch (17.8 mm) high LCD
Power .....	6 "AA" size Alkaline, Ni-Cad or NiMH batteries ( <i>not included</i> ) OR an optional 100 to 240 VAC 50/60Hz 12 VDC 1A wall plug-in UL/CSA listed AC power adapter (Cardinal part number 6800-1045).
Keyboard .....	Membrane type with 5 keys, On/Off, Lock/Release, Units, Zero, BMI/Enter and 4 directional arrows

<b>Serial Number</b> _____
<b>Date of Purchase</b> _____
<b>Purchased Form</b> _____
_____
_____
RETAIN THIS INFORMATION FOR FUTURE USE

<b>PRECAUTIONS</b>	
Before using this instrument, read this manual and pay special attention to all "WARNING" symbols:	
	
IMPORTANT	ELECTRICAL WARNING

## UNPACKING INSTRUCTIONS

- Remove scale from carton by lifting up with equal force from column and platform base.
- Remove all plastic wrapping, foam fillers and cardboard material from the scale.
- Place scale upside down on level, stable surface and remove all cardboard packing from bottom of scale base.
- Return scale to upright position and check for any damage incurred in shipping. If scale has been damaged, place a claim with the carrier. Use the original carton and shipping material to return the scale.
- Remove and unpack the AC power adapter, if the scale was ordered with this option.

## BABY TRAY INSTALLATION

1. Referring to Figure No. 1, remove the 2 flat head screws from the scale platform.
2. Place the baby tray on the scale platform and align the holes in the tray with the holes in the scale platform.
3. Attach baby tray to scale platform using the 2 flat head screws remove in step 1.  
**Do not over-tighten the screws.**
4. Scale is now ready for operation.

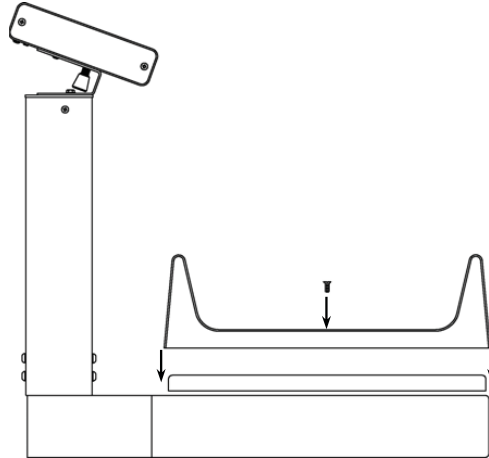

Figure No. 1

## CARE AND CLEANING OF SCALE

- **DO NOT** subject the platform to sudden shocks.
- **DO NOT** submerge indicator in water, pour or spray water directly on indicator.
- **DO NOT** use abrasive cleaners on this scale.
- **DO NOT** use acetone or other volatile solvents for cleaning.
- **DO** clean the scale and indicator using a damp soft cloth and mild detergent.
- **DO** avoid areas where the scale might be exposed to moisture.

## ERROR AND STATUS DISPLAYS

Display	Meaning
-Err-	General error, invalid keypad entry was attempted.
-OF-	Attempting to display a negative number greater than -9,999 or a positive number greater than 99,999.
-tRL-	Indicates an attempt to zero a weight outside scale zero range.
-UnS-	Motion is present when indicator is attempting to perform one of the following operations: Power Up Zero or Zero Weight Display.
CAL 16	Indicates calibration is necessary.
AdErr	Consult your scale service representative.
ErrAL	
ErrAH	
OCAP	Scale weight exceeds scale capacity.
OFF	Displayed to indicate indicator is turning off.

## OPERATION



**DO NOT** press the keys on the keypad with pointed objects (pencils, pens, etc). Damage to keypad resulting from this practice is **NOT** covered under warranty.

### Basic Weighing

1. Place scale on a level, stable surface.
2. With the baby tray empty, press **ON/OFF** key to turn on indicator.
3. Press **ZERO** key to zero weight display. The ZERO and lb or kg annunciator will turn on to show that scale is ready to weigh baby.
4. Lay baby being weighed in the center of baby tray. This will distribute the weight evenly across the scale platform.
5. Read weight display.
6. Remove baby from baby tray.



Figure No. 2

### Zero Weight Display

1. If the indicator is not showing zero weight on the display, press **ZERO** key.
2. Weight display will return to zero. The ZERO, STABLE  and lb or kg annunciators will turn on to show a stable, center-of-zero weight condition.

### Zero Weight Display with Item on Scale

1. Place item (blanket or similar covering) on scale.
2. Weight display will show weight of item on scale.
3. Press **ZERO** key.
4. Weight display will return to zero. The ZERO, STABLE  and lb or kg annunciators will turn on. The item's weight has been "zeroed off".
5. Proceed with weighing operation.

### Metric Conversion

Press **UNITS** key to toggle between pounds and kilograms. Note that lb or kg annunciator will turn on to show which weighing unit is active.



### CAUTION!

**Do not leave the baby unattended in the baby tray. Failure to maintain continual control of the baby can result in serious injuries should the baby fall from the baby tray.**

# BATTERY OPERATION

## Batteries

The scale can use 6 "AA" size Alkaline, Ni-Cad or NiMH batteries (*not included*). You must first obtain and install batteries before operations can begin. Batteries are contained in a battery holder inside indicator. Access is via a removable panel on the back of indicator.

When using batteries, all 6 batteries must be of the same type. They must be all Alkaline, Ni-Cad or all NiMH. In addition, **DO NOT** mix Ni-Cad or NiMH batteries.



**IMPORTANT!** The scale can be operated from Alkaline, Ni-Cad or NiMH batteries. All six (6) batteries must be of the same type. They must all be Alkaline, all Ni-Cad or all NiMH. **DO NOT** mix Alkaline and Ni-Cad or NiMH batteries.



**CAUTION!** The AC power adapter is also used to recharge the batteries, when the scale is operated from Ni-Cad or NiMH batteries. **DO NOT** connect the AC power adapter to the scale if using Alkaline batteries. Also, when using Alkaline batteries, make sure *n i C a d* setup option is disabled (set to 0). Refer to Setup and Calibration or Setup Review sections of 750 Weight Indicator Owner's Manual (8555-M260-O1).

## Battery Installation/Replacement

To install or remove the batteries, the following steps should be followed:

1. Make sure the AC power adapter is unplugged.
2. Remove the indicator from scale column bracket. (Referring to Figure No. 3, pull the spring plunger down and slide the indicator up away from the bracket).
3. Turn the indicator over so that the display is facing away from you.



Figure No. 3

4. Locate the rectangular panel on back of indicator.
5. To install or replace the batteries, first remove the battery holder cover by pushing in on the tab and lifting it up. Refer to Figure No. 4.



Figure No. 4

**For more information on setup and operation of the indicator, see the 750 Owner's Manual (8555-M260-O1).**

## BATTERY OPERATION, CONT.

6. If installing new batteries, proceed to step 7. If replacing the batteries, remove all 6 batteries from the battery holder and then proceed to step 7.
7. Install the 6 new “AA” size batteries in the battery holder, noting the polarity markings located in the battery holder. Refer to Figure No. 5.
8. After placing all 6 batteries in the holder, replace the battery cover.
9. Turn the indicator over (display facing up) and press the **ON/OFF** key.
10. If display turns on, batteries have been installed correctly. If not, remove panel and check for one or more improperly positioned batteries.
11. Return indicator to scale column bracket.
12. The scale is now ready for operation.



Figure No. 5

### Indicator Installation

To install the indicator on the scale column bracket, place the screw heads on the back of the indicator into the large end of the slotted holes in the bracket. Pull down to secure the indicator. The spring plunger will lock the indicator to the bracket. See Figures No. 6, 7 and 8.

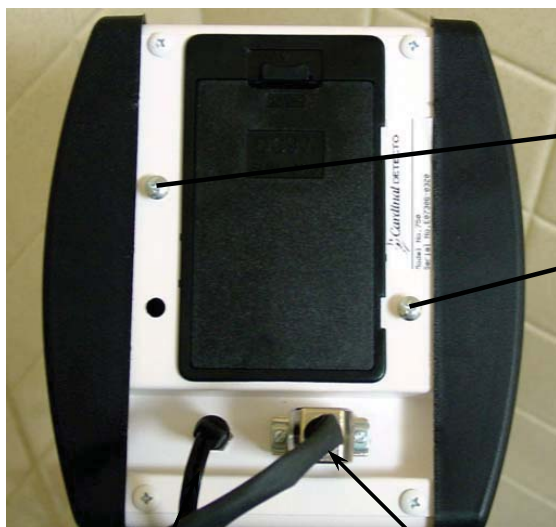

AC Power Adapter

Figure No. 6

Scale Cable

Figure No. 8

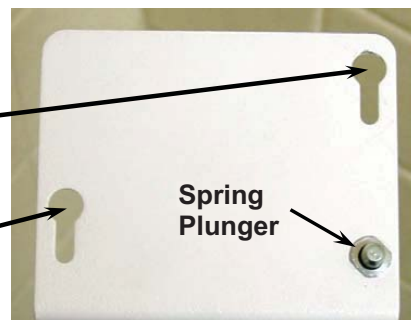

Figure No. 7



Spring Plunger Release

## OPTIONAL AC POWER ADAPTER

To power the scale using the optional 12 VDC wall plug-in AC power adapter, connect the plug from the adapter into the power jack on the back of the indicator and then plug the power adapter into the proper electrical outlet. Refer to Figure 6. On models requiring 230 VAC, it is the customer's responsibility to obtain the correct power adapter plug.

# PARTS IDENTIFICATION

## FINAL ASSEMBLY

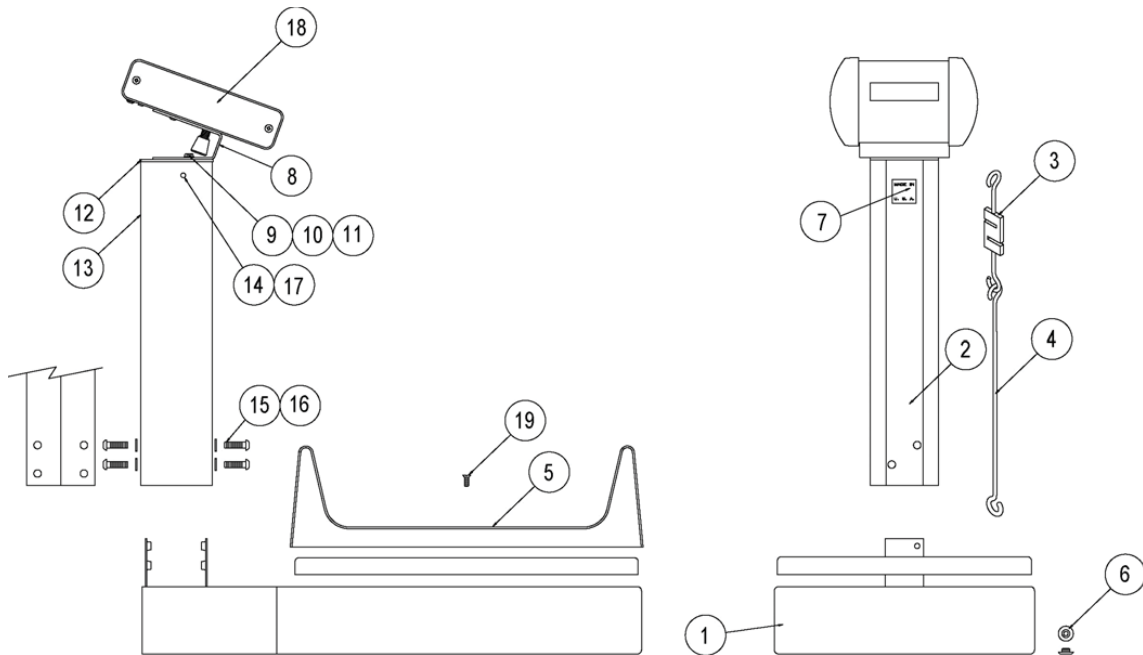

ITEM	QTY	PART NUMBER	DESCRIPTION
1	1	33P1201X-1	BASE ASSEMBLY
2	1	430XG3R804	COLUMN WELDMENT
3	1	709G2R1204	LOAD CELL & MOUNTING ASSEMBLY
4	1	0033-B255-08	DRAFT ROD FOR (8435)
5	1	33P50	BABY TRAY
6	4	63K1038	BASE LEG
7	1	5930-B114-08	LABEL: SCALE MODEL NO. SHEET 7
8	1	0033-B439-0A	MOUNTING BRKT
9	1	391RV204	NUT ELASTIC STOP 1/4-20 Z/P
10	1	6021-1454	SCW HEX HEAD 1/4 -20 X 3/4
11	1	6024-0004	WASHER FLAT 1/4
12	1	0033-B104-0A	TOP PLATE ASSY.
13	1	593R986	SERIAL TAG
14	2	6024-0049	WASHER LOCK EXT #10
15	6	6024-0047	WASHER LOCK EXT 1/4
16	6	6021-1423	SCW TRUSS HEAD 1/4-20 X 1/2
17	2	6021-1045	SCW HEX HEAD #10-32 X 1/2 Z/P
18	1	750	DIG. WT. INDICATOR
19	2	6021-0868	SCW FLAT-HEAD. MACHINE-SCW 08-32X.500
*	1	6800-1045	OPTIONAL AC ADAPTER 100-240VAC/12VDC @ 1A

\* NOT SHOWN



# PARTS IDENTIFICATION, CONT.

## BASE ASSEMBLY

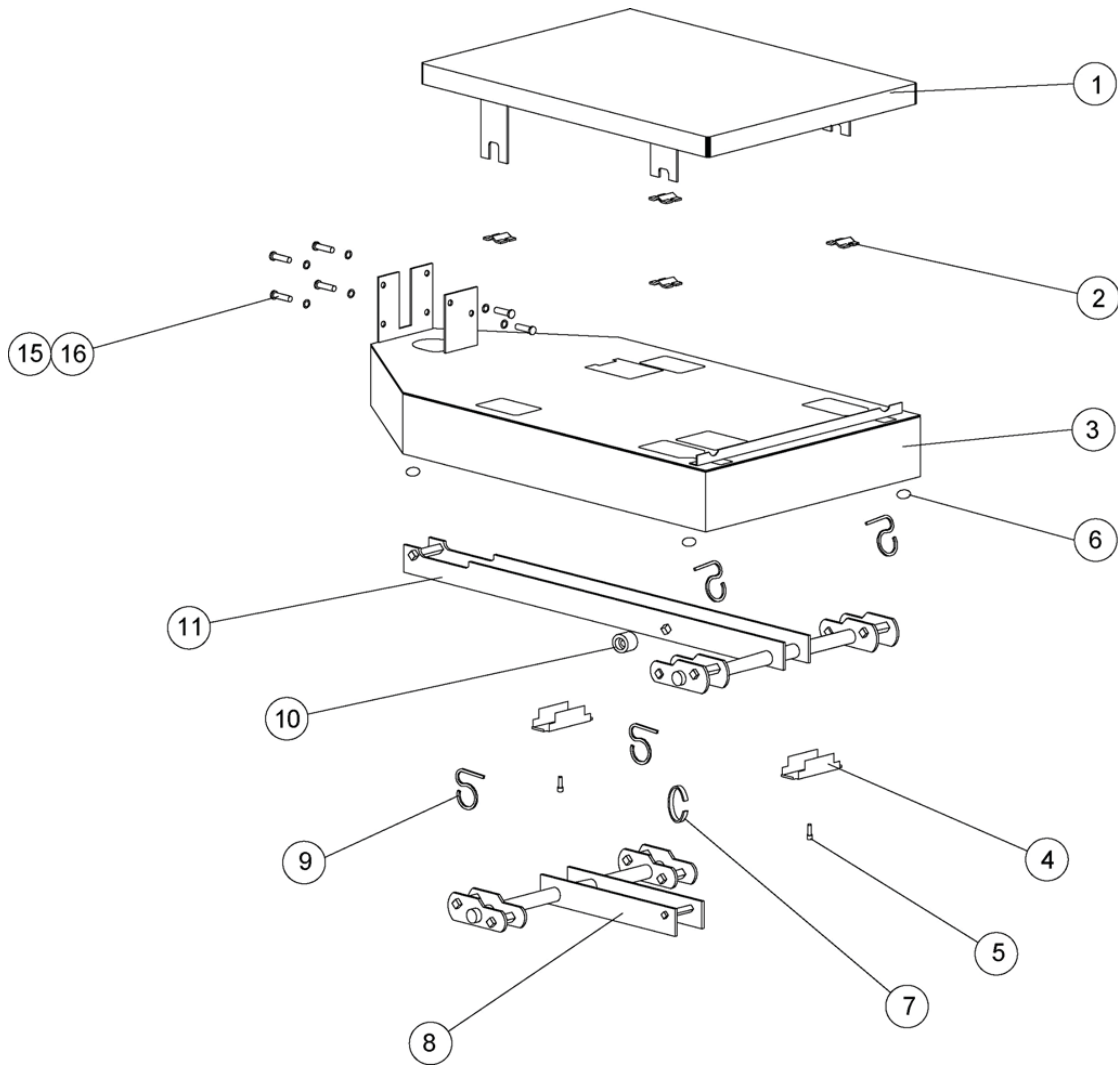

ITEM	QTY	PART NUMBER	DESCRIPTION
1	1	33P1011X	PLATFORM WELDMENT
2	4	3P2087	PLATFORM LOAD BEARING
3	1	3P1001X	BASE WELDMENT
4	2	3P60	CHECK PLATE
5	2	6021-0985	HEX WASHER HD SCW #10 X 1/2
6	4	63K1038	BASE LEG
7	1	2U58	UNION CENTER HANGER
8	1	3P8003X	SHORT LEVER ASSEMBLY
9	4	3P8059	UNION HANGER
10	1	3P122	BUMPER
11	1	3P8002X	LONG LEVER ASSEMBLY
15	6	6024-0047	WASHER LOCK EXT 1/4
16	6	6021-1423	SCW TRUSS HEAD 1/4-20 X 1/2

## STATEMENT OF LIMITED WARRANTY

Detecto Scale warrants its equipment to be free from defects in material and workmanship as follows: Detecto warrants to the original purchaser only that it will repair or replace any part of equipment which is defective in material or workmanship for a period of one **(1) year** from date of shipment. Detecto shall be the sole judge of what constitutes a defect.

During the **first ninety (90) days** Detecto may choose to supply all necessary replacement parts and service during normal weekday working hours at no charge to the buyer.

**After the first ninety (90) days** Detecto will supply parts and service at the job site provided the owner agrees to pay the Dealer for all travel time, including mileage and test equipment, as well as any expenses incurred over the direct labor of the technician at the job site. This limited warranty honors only labor performed by Detecto authorized dealers.

This warranty does not apply to peripheral equipment not manufactured by Detecto; this equipment will be covered by certain manufacturer's warranty only.

This warranty does not include replacement of expendable or consumable parts. This does not apply to any item which has deteriorated or damaged due to wear, accident, misuse, abuse, improper line voltage, overloading, theft, lightning, fire, water or acts of God, or due to extended storage or exposure while in purchaser's possession. This warranty does not apply to maintenance service. Purchased parts will have a ninety (90) day repair or replacement warranty only.

Detecto may require components be returned to the factory; they must be properly packed and shipping charges prepaid. A return authorization number must be obtained for all returns and marked on the outside of all returned packages. Detecto accepts no responsibility for loss or damage in transit.

# STATEMENT OF LIMITED WARRANTY

## Conditions Which Void Limited Warranty

This warranty shall not apply to equipment which:

- A.) Has been tampered with, defaced, mishandled or have had repairs and modifications not authorized by Detecto.
- B.) Has had serial number altered, defaced, or removed.
- C.) Has not been grounded according to Detecto's recommended procedure.

## Freight Carrier Damage

Claims for equipment damaged in transit must be referred to the freight carrier in accordance with freight carrier regulations.

This warranty sets forth the extent of our liability for breach of any warranty or deficiency in connection with the sale or use of the product. Detecto will not be liable for consequential damages of any nature, including but not limited to, loss of profit, delays or expenses, whether based on tort or contract. Detecto reserves the right to incorporate improvements in material and design without notice and is not obligated to incorporate improvements in equipment previously manufactured.

The foregoing is in lieu of all other warranties, express or implied including any warranty that extends beyond the description of the product including any warranty of merchantability or fitness for a particular purpose. This warranty covers only those Detecto products installed in the forty-eight (48) contiguous continental United States.



Ph. (800) 641-2008  
E-mail: [detecto@cardet.com](mailto:detecto@cardet.com)  
203 E. Daugherty  
Webb City, MO 64870

02/06  
Printed in USA  
D268-WARRANTY-DET

